

Designer Series™ DSG-80000 and DSOF-80000 Sinks

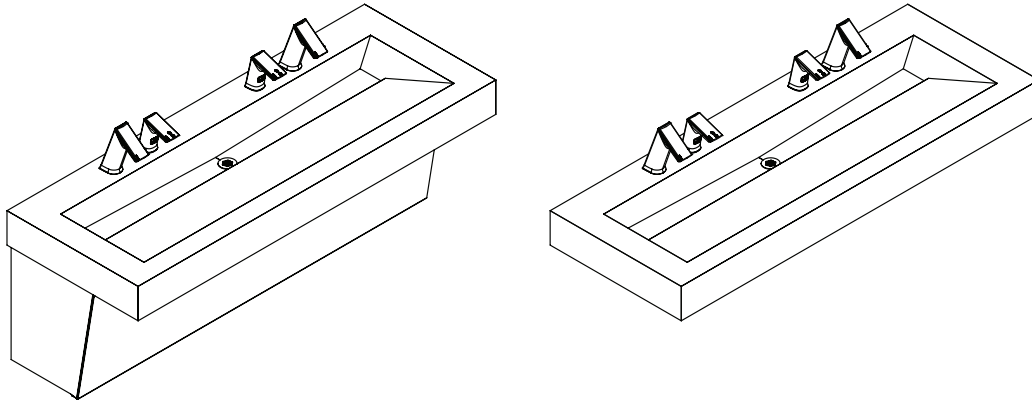

Sink Location

Determine the appropriate wall location for the Lavatory System. Consider that hot and cold water supply lines, a drain line, and an electrical source (receptacle for hardwired faucets and hand dryer) will be required. Compare the physical dimensions of the Lavatory System to the space available for the installation. If wall is not load bearing, a carrier may be required behind the wall. Refer to the appropriate Rough-in diagrams for Lavatory System dimensions. Prior to Lavatory System installation, electric wiring, water supply and drain must be installed.

DSG-82000, Two Station Components

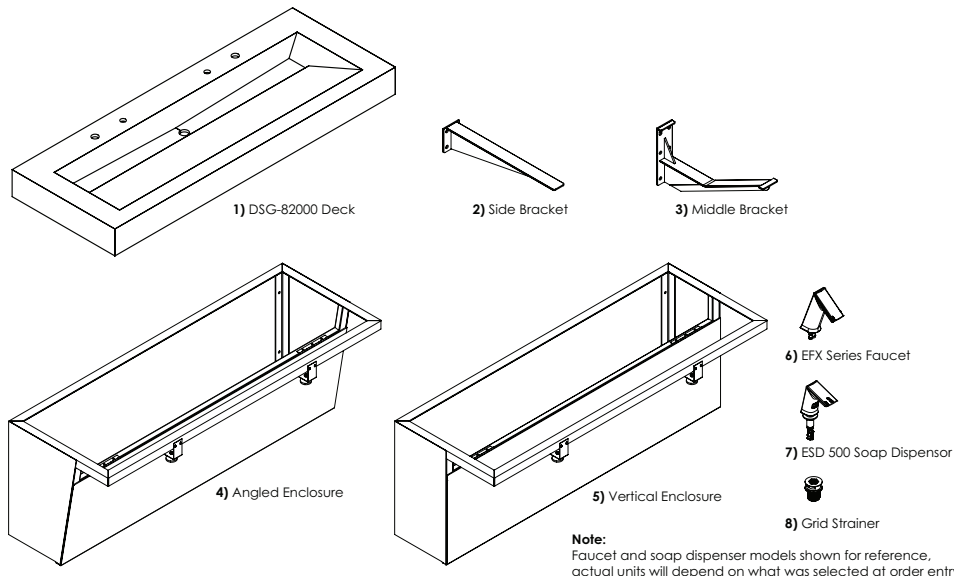

DSG-82000, Two Station Component List

Description	Item Number	Quantity
Designer Series Gradient, Two Station, Deck	1	1
Side Bracket (Mounting Option)	2	2
Middle Bracket (Mounting Option, not required for single station)	3	2
Angled Enclosure with Hold Open Door (Mounting Option)	4	1
Vertical Enclosure with Hold Open Door (Mounting Option)	5	1
EFX Series Faucet	6	2
Basys Style ESD 500 Soap Dispenser Note: If ESD-500 Selected – Area under the sink must be clear for proper installation access and soap bottle change (no outlets, stops, etc).	7	2
Grid Strainer	8	1

Designer Series™ DSG-80000 and DSOF-80000 Sinks

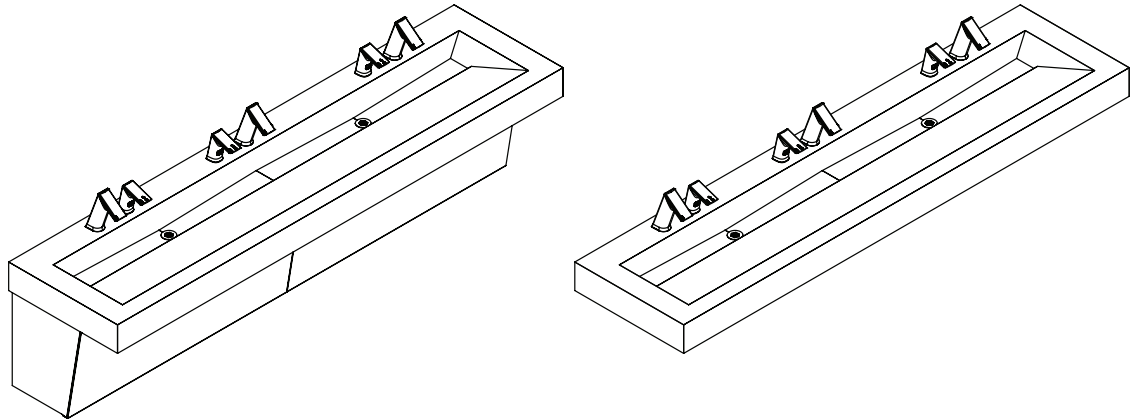

Sink Location

Determine the appropriate wall location for the Lavatory System. Consider that hot and cold water supply lines, a drain line, and an electrical source (receptacle for hardwired faucets and hand dryer) will be required. Compare the physical dimensions of the Lavatory System to the space available for the installation. If wall is not load bearing, a carrier may be required behind the wall. Refer to the appropriate Rough-in diagrams for Lavatory System dimensions. Prior to Lavatory System installation, electric wiring, water supply and drain must be installed.

DSG-83000, Three Station Components

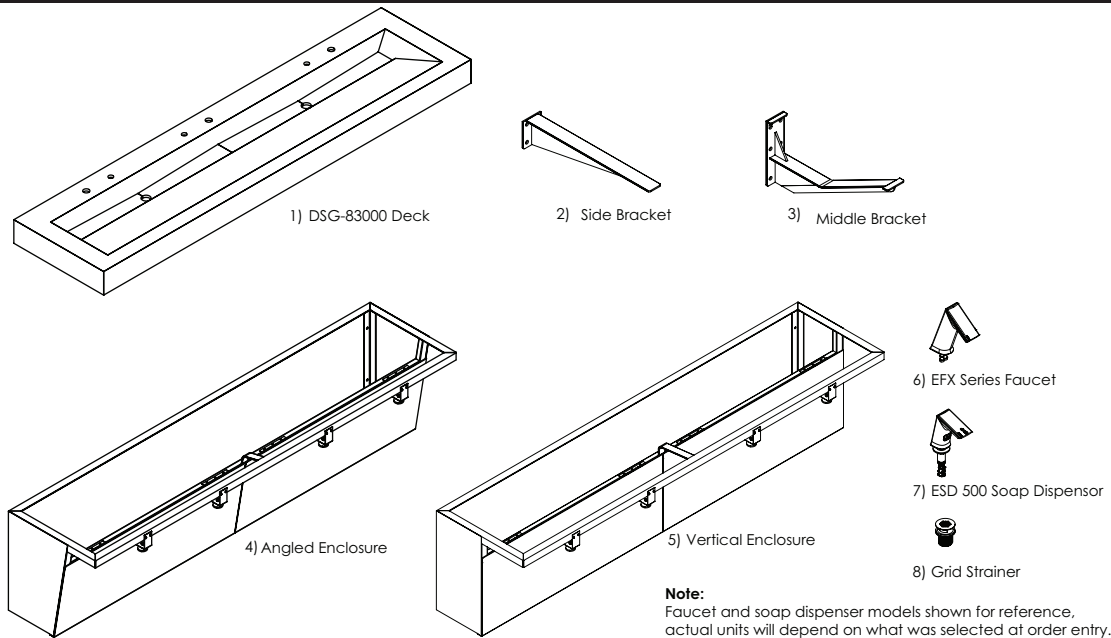

DSG-83000, Three Station Component List

Description	Item Number	Quantity
Designer Series Gradient, Three Station, Deck	1	1
Side Bracket (<i>Mounting Option</i>)	2	2
Middle Bracket (<i>Mounting Option, not required for single station</i>)	3	4
Angled Enclosure with Hold Open Door (<i>Mounting Option</i>)	4	1
Vertical Enclosure with Hold Open Door (<i>Mounting Option</i>)	5	1
EFX Series Faucet	6	3
Basys Style ESD 500 Soap Dispenser Note: If ESD-500 Selected – Area under the sink must be clear for proper installation access and soap bottle change (no outlets, stops, etc).	7	3
Grid Strainer	8	2

Designer Series™ DSG-80000 and DSOF-80000 Sinks

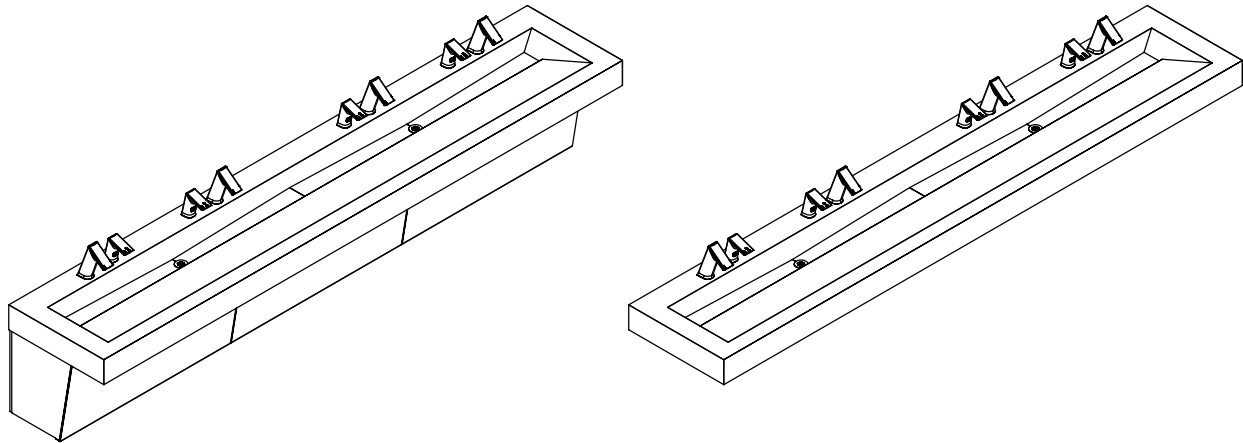

Sink Location

Determine the appropriate wall location for the Lavatory System. Consider that hot and cold water supply lines, a drain line, and an electrical source (receptacle for hardwired faucets and hand dryer) will be required. Compare the physical dimensions of the Lavatory System to the space available for the installation. If wall is not load bearing, a carrier may be required behind the wall. Refer to the appropriate Rough-in diagrams for Lavatory System dimensions. Prior to Lavatory System installation, electric wiring, water supply and drain must be installed.

DSG-84000, Four Station Components

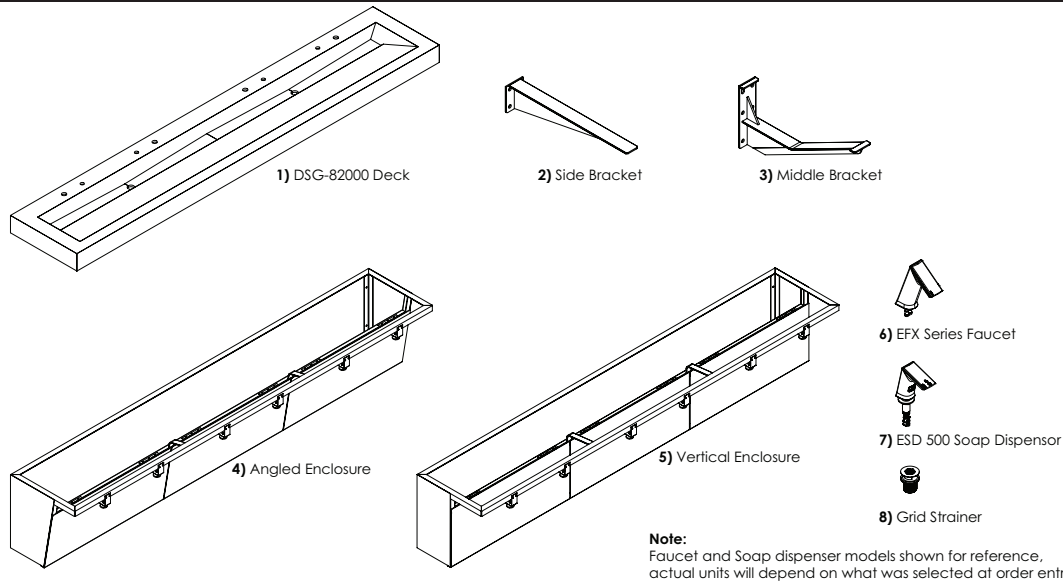

DSG-84000, Four Station Component List

Description	Item Number	Quantity
Designer Series Gradient, Four Station, Deck	1	1
Side Bracket (Mounting Option)	2	2
Middle Bracket (Mounting Option, not required for single station)	3	6
Angled Enclosure with Hold Open Door (Mounting Option)	4	1
Vertical Enclosure with Hold Open Door (Mounting Option)	5	1
EFX Series Faucet	6	4
Basys Style ESD 500 Soap Dispenser Note: If ESD-500 Selected – Area under the sink must be clear for proper installation access and soap bottle change (no outlets, stops, etc).	7	4
Grid Strainer	8	2

Designer Series™ DSG-80000 and DSOF-80000 Sinks

TROUBLESHOOTING GUIDE

Refer to appropriate faucet pages in Maintenance Guide.

1. No water flows when sensor is activated

Ensure that main power supply is turned "ON." Check receptacle, transformer, batteries (battery powered models), solenoid, leads and connections.

INDICATOR: If Sensor LED does not blink:

- A. Control module circuit board is faulty; replace.
- B. Sensor is faulty; replace sensor module.

INDICATOR: If Sensor LED blinks when user is sensed:

- A. Supply Stop(s) may be closed; open Supply Stop(s).
- B. Debris may be in Solenoid filter; remove, clean and reinstall.

2. Very low flow or slow dribble

- A. Supply Stop(s) may be closed; open Supply Stop(s).
- B. Debris is in solenoid, won't close properly; remove operator and clean. Reassemble in the same manner.
- C. Debris may be in Solenoid filter; remove, clean and reinstall.
- D. Debris is in aerator; remove, clean and reinstall.

3. Continues to run (even after power to faucet has been disconnected)

- A. Solenoid valve is installed backwards; install correctly.
- B. Debris is in solenoid, won't close properly; remove operator and clean. Reassemble in the same manner.

Solenoid Screen Filter Cleaning

- A. Before cleaning the Screen Filter, turn off the water supply at supply stop(s).
- B. Activate the Faucet to relieve any pressure in the system.
- C. Unscrew the Filter Cap and remove it from the Solenoid Valve Housing.
- D. Carefully remove the Screen Filter from the Solenoid Valve Housing.
- E. Clean the Screen Filter using fresh tap water only. If necessary, use a small brush to clean.
Use caution while cleaning to prevent damage to Screen Filter.
- F. Examine the Copper Washer or O-ring for wear or damage; replace if necessary. Carefully replace the Screen Filter into Filter Cap. Screw the Filter Cap with Copper Washer or O-ring into Solenoid Valve Housing and tighten securely to prevent leaks.
- G. Turn on the water supply at the supply stop(s). Activate the Faucet to purge any air from the system lines. Check for leaks and repair as necessary.

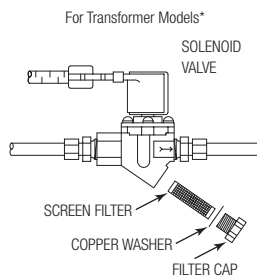

Material Description: Corian Material is made from a blend of acrylic modified bio-based polyester resin. Engineered Stone is 90% natural quartz and polyester resin and is resistant to chemicals, stains, burns and impact. Surface damage can be easily repaired with everyday cleansers or fine grit abrasives.

Routine Cleaning: For regular cleaning, use standard commercial or household products such as Simple Green®, Creamy Cleanser brand, Formula 409® or Windex®.

Stubborn Stains: Remove tough stains, with non abrasive cleaners and pads such as a white Scotch Brite® pad and Lysol®. Special Situations for Corian and Engineered Stone

Hard Water Deposits: Remove hard water deposits with a mild solution of vinegar and water. Always rinse the unit thoroughly after cleaning.

Repair Kits: Corian repair kits are available. Contact your Sloan Stone Sink Systems representative or distributor for part numbers and pricing. Repair kits are made to order and have a shelf life of 30 days. Engineered Stone shades of color can vary from product to product.

BRAND NAMES

Use of brand names is intended only to indicate a type of cleaner. This does not constitute an endorsement, nor does the omission of any brand name cleaner imply inadequacy. Many products named are regional in distribution, and can be found in local supermarkets, department and hardware stores, or through your cleaning service. It is emphasized that all products should be used in strict accordance with package instructions.

**When assistance is required, please contact
Sloan Technical Support at: 1-888-SLOAN-14 (1-888-756-2614).**