

INSTALLATION INSTRUCTIONS FOR DROPSPOT™ ON-WALL BOTTLE FILLERS

DRS-120 Bottle Filler with Bi-Level Cooler



SLOAN® LIMITED WARRANTY SUMMARY

Sloan Valve Company (“Sloan”), warrants its products against defects in materials and workmanship, excluding damage caused by matters beyond Sloan’s reasonable control. Instructions for filing claims can be found in the Limited Warranty which can be obtained at www.sloan.com or by requesting a free copy by telephone at 888.756.2614. Sloan will repair or replace your defective product, or provide a refund, as your exclusive remedy. This is only a general summary of Sloan’s Limited Warranty so it is important to note that the specific terms, conditions, limitations and exclusions, including the duration of warranty coverage for your particular Sloan product, are contained in the actual Sloan Limited Warranty. The Limited Warranty is subject to applicable laws in your country, state, province or other jurisdiction—and disputes arising under the Limited Warranty are to be resolved by binding arbitration unless you provide Sloan with an opt-out notice no later than 30 days after your purchase date. In case of a conflict with this summary, the terms and conditions set forth in the complete Limited Warranty will prevail.

IMPORTANT INFORMATION

Some options may slightly alter installation. **To ensure proper installation, review this document thoroughly and verify rough-ins before beginning any work.** File this document with the owner or maintenance personnel upon completion of installation.

Sloan products are designed in accord with applicable National Codes and Standards, which may include UPC, ANSI, and ASSE. Installers should use industry standard practice for details not covered within this document. ANSI, UFAS or ADA compliance is subject to the interpretation and requirements of the local code authority and is the responsibility of the installer for verification.

Prior to installation, supply lines must be flushed of all foreign material such as pipe dope, chips, or solder. Debris or foreign material in water supply may damage valve. An appropriate thread sealant is recommended on all MPT threaded waste and supply connections to reduce the possibility of leaks. Thread sealant NOT recommended for slipjoint or gasketed connections.

Industry standard wall backing substrate, for wall hung fixtures, is required. Installer provided wall anchors and wall anchoring hardware must be appropriate for wall construction and be able to support three (3) times the weight of the unit.

Electrical receptacle(s) must be wired to a GFCI protected circuit. Fixture must be earth grounded per NEC (National Electrical Code). This fixture is intended to dispense water that has been lowered in temperature, but otherwise remains unchanged by the materials in the water cooler. It is common for electrical equipment to be grounded to water lines either within a structure or away from it. Every attempt should be made to prevent this kind of grounding from generating electrical feedback into the water cooler creating electrolysis. Electrolysis will cause a metallic taste or cause water metal content to increase.

NOTICE: A dielectric coupling must be used to connect the water cooler to the water supply. A nonmetallic coupler is furnished with this water cooler to meet this requirement.

IMPORTANT INFORMATION, CONTINUED

- This fixture is intended for **indoor use only** and is not recommended for installation in environments where freezing temperatures or saltwater may be present.
- Water supply service stop valve, water connections and electrical connections (not provided) must be in accordance with local codes.
- Waste is 1-1/4" Outer Diameter. Water supply is 3/8" Outer Diameter copper pipe.
- To prevent excessive condensation due to cold waste water, Sloan recommends that waste piping (not provided) be insulated appropriately.
- Water cooler is designed to not interfere with taste, odor, color, or sediment of water supply. Optional Water Filter is available should any of these problems arise from the water supply. See part number on page 12.
- **DO NOT** solder tubes inserted into the chiller, bottle filler, or the fountain strainer as damage to the O-rings on the push-in fittings may result.
- All burrs must be removed from outside of the cut tubes before inserting into the components.
- Power supply must be identical in voltage, cycle, and phase to that specified on the chiller data plate. This unit must be grounded per the

requirements of applicable electrical codes.

- Fixture operates within water pressure range of 20 psi (138 kPa) to 105 psi (724 kPa). Sloan will not warranty product damaged when connected to supply lines with flow pressure lower than 20 psi (138 kPa) or higher than 105 psi (724 kPa). A pressure regulator must be furnished (not provided) on supply line if inlet pressure is greater than 105 psi (724 kPa). **Consult with UPC and local codes for maximum allowable water pressures; many building codes list maximum static water pressure at 80 psi (551 kPa).**
- Per UPC 609.10 – All building water supply systems in which quick acting valves are installed shall be provided with devices to absorb the hammer caused by high pressure resulting from the quick closing of the valve. These pressure-absorbing devices must be approved mechanical devices. Water pressure-absorbing devices must be installed as close as possible to the supply stop.
- **WARNING:** Warranty is voided if installation is not made following current Sloan installation instructions and if components are assembled to the fixture that are not approved by Sloan.

PRIOR TO INSTALLATION

1. Read installation instructions carefully and completely before proceeding.
2. Use caution when handling units as sharp edges may be present.
3. Provide mounting surface, adequate to support three (3) times the weight of the fixture (270 lbs.).
4. Provide rough-ins as shown on the rough-ins and dimensional drawing, including water supply and drain pipe. (See **Rough-in**).
5. If the refrigerated unit was tipped during transport, the unit must be in the upright position for 24 hrs. or equal to the amount of time it was sideways.

6. It is common for electrical equipment to be grounded to water lines either within a structure or away from it. Every attempt should be made to prevent this kind of grounding from generating electrical feedback into the water cooler creating electrolysis. Electrolysis will cause a metallic taste or cause water metal content to increase.
7. Electrical Receptacle(s) must be wired to a GFCI protected circuit. Fixture must be earth grounded per NEC (National Electrical Code).
8. **Completely flush water supply lines of all foreign debris,** before connecting to the fixture.

TOOLS REQUIRED FOR INSTALLATION

- 1/4" Flathead Driver (not provided)
- 5/32" Hex Driver or Allen Wrench (not provided)
- Anchoring hardware for $\varnothing 7/32$ " holes in Step 2E (not provided)
- Phillips head screwdriver (not provided)

- Power drill (not provided)
- Level (not provided)
- Universal Maintenance Tool (provided)



Universal Maintenance Tool
DO NOT DISCARD!

DIMENSIONAL DRAWING

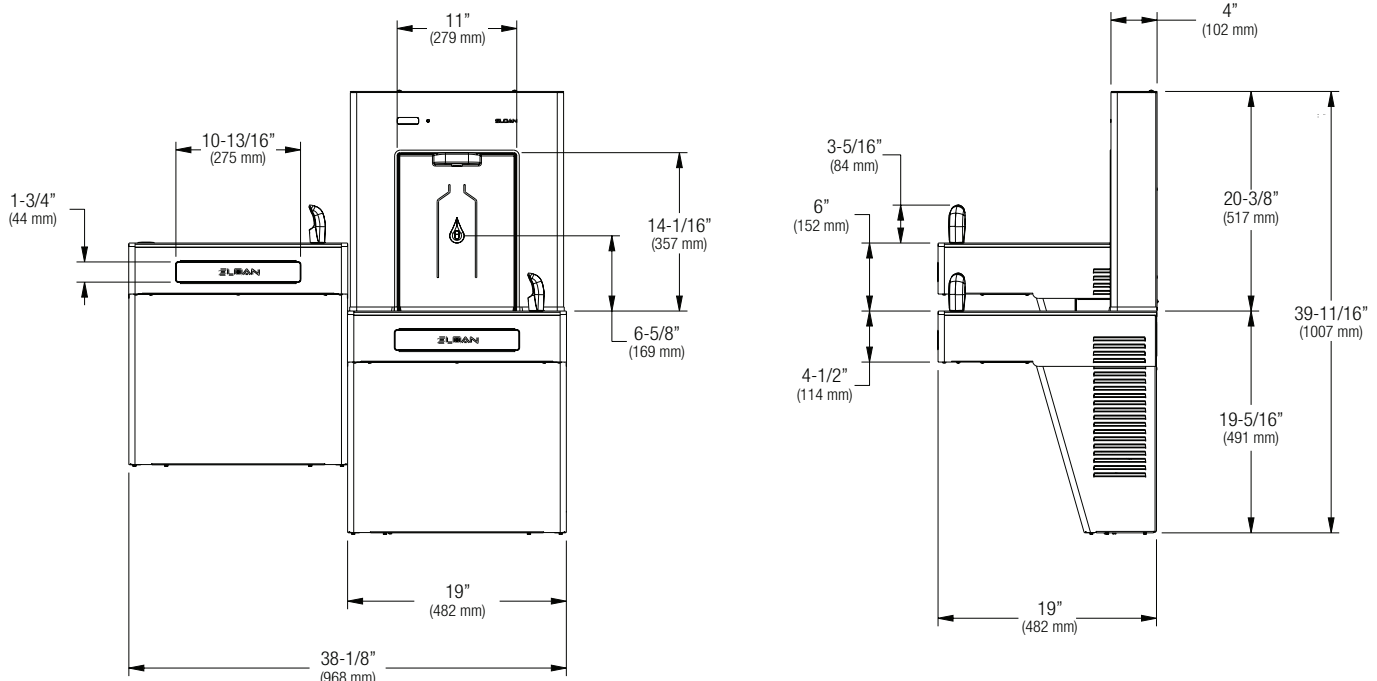

ROUGH-IN

Prior to roughing in, consult local, state, and federal codes for proper mounting height.

STANDARD CONFIGURATION – Left Unit High, Right Unit Low

For alternate configurations, visit sloan.com.

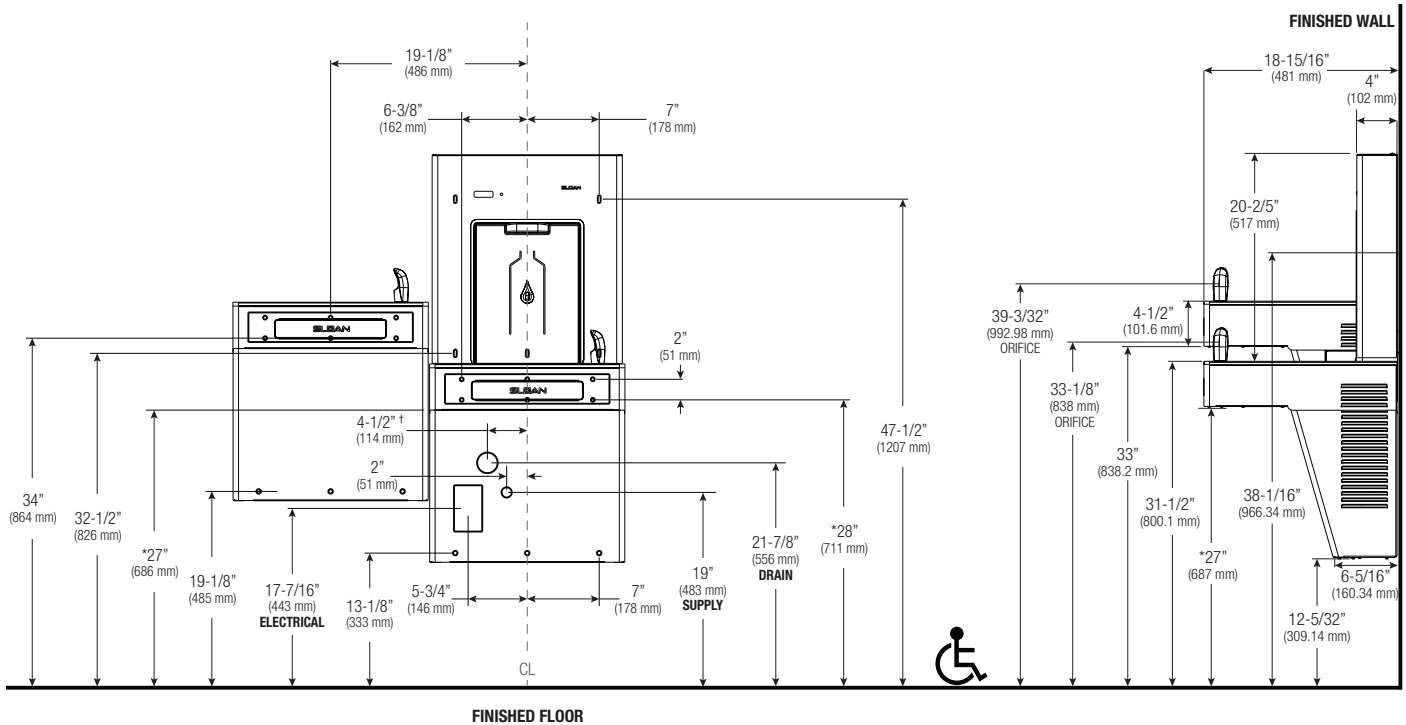

NOTES:

- All dimensions are shown in inches (mm).
- Allow 4 inches (102 mm) minimum clearance per side for ventilation.
- Dimensions indicated with an asterisk (*) are for ADA frontal approach installation. Adjust vertical dimension (*) as required to comply with federal, state, and local codes. For Child ADA compliant parallel approach, decrease the bubbler spout height to 30" maximum above finished floor. Provide clear floor space as required. Compliance is subject to the interpretation and requirements of the Local Code Authority.
- **IMPORTANT: UNITS MUST BE ATTACHED TO WALL WITH APPROPRIATE ANCHOR SCREWS (not provided).**
- Refrigerated unit must be on the right side.
- Dry weight of unit: 90 lbs.
- Waste P-Trap, Water Supply Service Angle Stop Valve and 2" x 4" Electrical Plug-In Receptacle (not provided) must be installed in accordance with local codes. A P-Trap (not provided) must be used for the drain connection.
- Water supply is 3/8" Outside Diameter copper tube. Waste is 1-1/4" Outside Diameter.
- † 4-1/2" is the recommended distance from the centerline to the drain, however, depending on the application and existing rough-in, 3-7/8" to 4-7/8" is acceptable.

WASTE CONFIGURATION

STANDARD WASTE CONFIGURATION

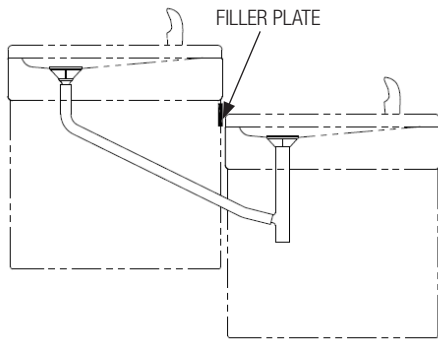

ALTERNATE WASTE CONFIGURATION

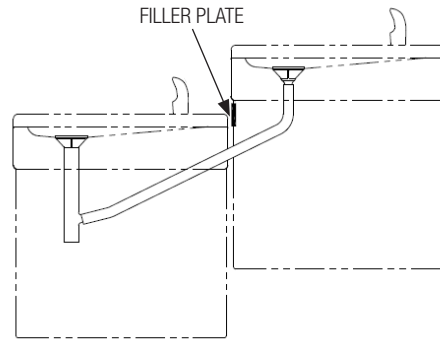

TUBING AND WATERPATH

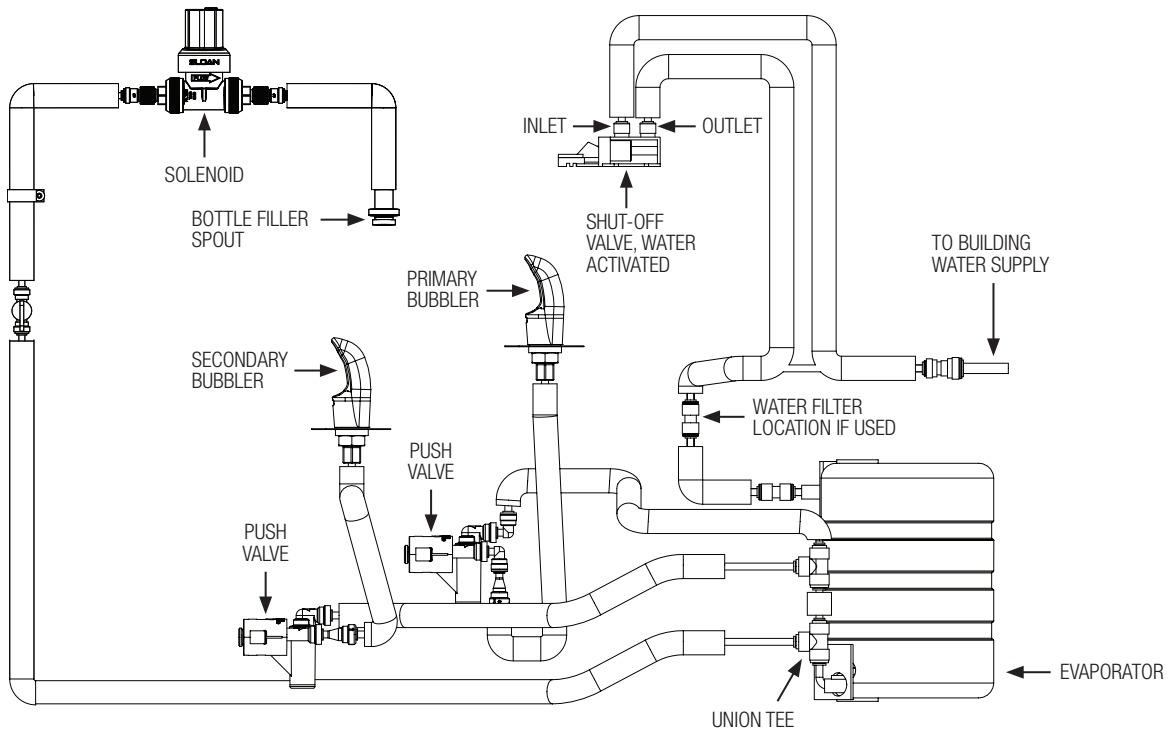

ELECTRICAL REQUIREMENTS AND CONNECTIONS

Electrical Requirements:

- Provide Duplex Receptacle on GFCI Protected Circuit
- 115VAC, 60Hz, 5A

Power supply must be identical in voltage, cycle, and phase to that specified on the cooler data plate. Electrical outlet and furnished power cord with plug must be used to supply power to cooler. **DO NOT** wire compressor directly to the power supply.

NOTE: Two (2) outlets are required; one (1) for the Cooler and one (1) for the Bottle Filler.

Electrical Receptacle(s) must be wired to a GFCI protected circuit. Fixture must be earth grounded per NEC (National Electrical Code).

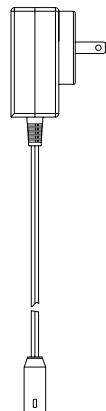

Bottle Filler Power Supply

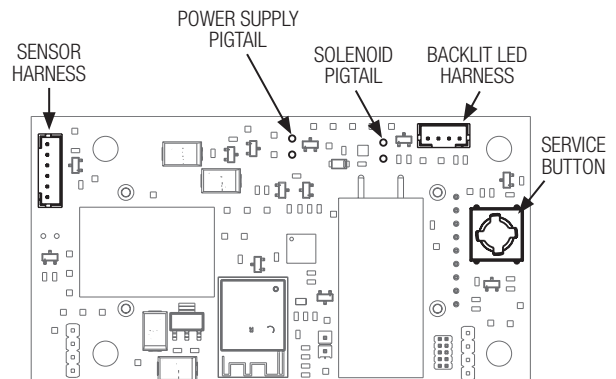

Bottle Filler Control Board Rear View

PUSH-IN FITTINGS

NOTE: FITTINGS AND TUBE SHOULD BE KEPT CLEAN, BAGGED, AND UNDAMAGED PRIOR TO INSTALLATION.

TO CUT TUBE

If needed, use a common PE tubing cutter, scissors, or a razor blade to cut to fit length of 1/4" tubing and remove any burrs or sharp edges. Ensure that the outside diameter is free from score marks. Tube ends should be square.



INSERTING THE TUBE

- 1 Firmly and fully insert the tubing end into the push-in fitting up to the tube stop located approximately 1/2" deep.
- 2 Pull on the fitted tubing to ensure it is secure. Tube should not come free from the fitting. Water test the connection assembly to ensure there are no leaks.

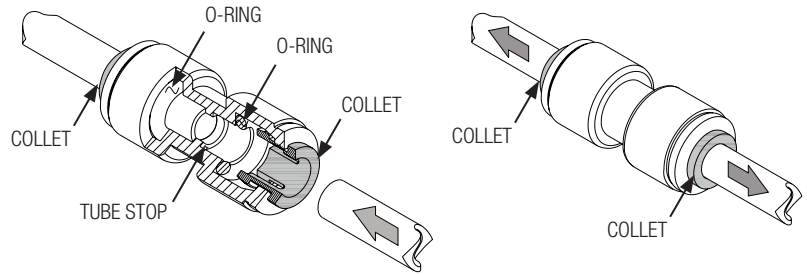

DISCONNECTING THE TUBE

To disconnect the tube from the fitting, ensure that the water line is depressurized. Use the Sloan Universal Maintenance Tool to push collet square/evenly towards the push-in fitting body and hold. While holding the collet in, pull on the tubing to remove from the push-in fitting.

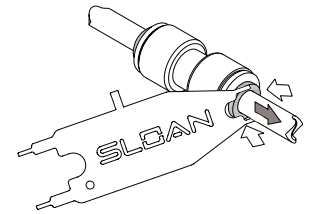

1 – INSTALLATION PREPARATION

IMPORTANT: Prior to Bottle Filler installation, adequate structural support in or behind the wall, water supply, drain, and electrical must be installed.

All plumbing should be installed in accordance with applicable codes and regulations. All electrical wiring should be installed in accordance with national and local codes and regulations. Electrical outlets should be recessed and installed prior to Bottle Filler installation.

A Adequate Wall Support

Industry standard wall backing substrate for wall hung fixtures is required. Installer provided wall anchors and wall anchoring hardware must be appropriate for wall construction and be able to support three (3) times the weight of the unit (270 lbs.).

B Water Supply

3/8" OD Supply Inlet.

C Drain Line

1-1/4" OD Waste Outlet.

D Electrical

Receptacle(s) must be GFCI protected. Fixture must be earth grounded per National Electric Code (NEC).

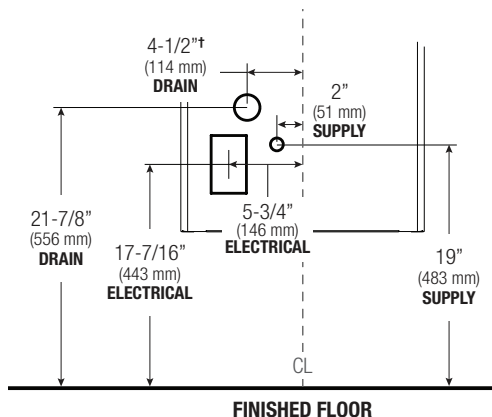

† 4-1/2" is the recommended distance from the centerline to the drain, however, depending on the application and existing rough-in, 3-7/8" to 4-7/8" is acceptable.

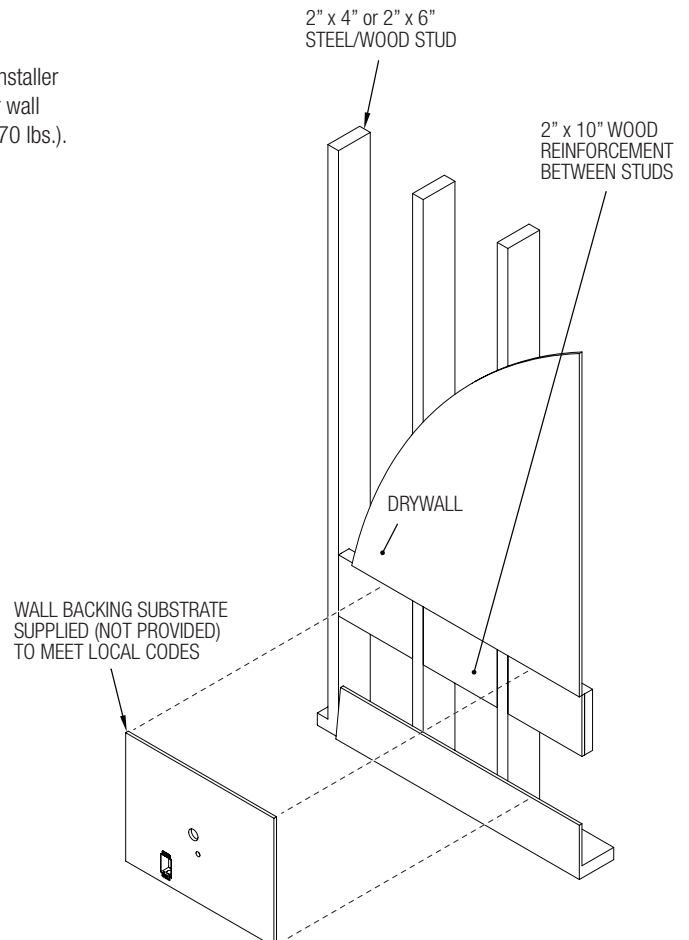

2 – INSTALL COOLERS

- A** Choose configuration.
For alternate mounting configuration, remove and reinstall filler plate and reverse drain assembly. See **Waste Configuration** on page 4.

- B** Mount hanger brackets to wall horizontally level as shown in rough-in.
NOTES: Adjust height of bracket if outlet height is required to vary from shown. Hanger brackets **MUST** be securely anchored to wall with fasteners sufficient to support three (3) times the weight of the unit (270 lbs.).

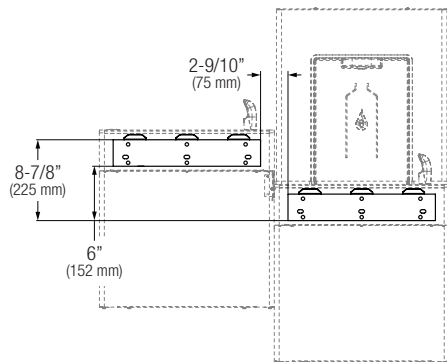

- C** Using a 1/4" flathead driver, remove the lower shrouds/covers from the coolers. Set aside for later use.

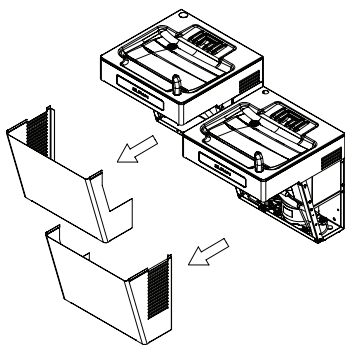

- D** **NOTE:** This may be a two-person step.
Hang the coolers on the hanger brackets ensuring the bracket tabs engage AND fit completely into the slots in the back of the coolers.
Hang the refrigerated unit first since it is the heavier of the two.
Verify coolers are level – left to right AND front to back from bottom of unit.
NOTE: The bubbler stream may be adversely affected if units are not square and level. The bottom of the units should be used as reference to verify the units are plumb.

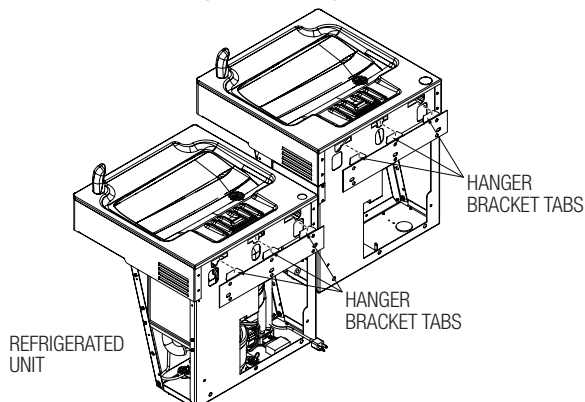

- E** Anchor the units to the wall at the lower mounting points in each back panel. Shim lower mounting points between the wall and mounting plates to level units if necessary.

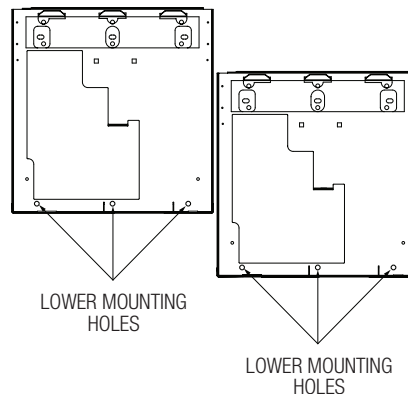

- F** Connect the loose supply tubing running from the non-refrigerated unit to the in-line union tee on the evaporator. Refer to **Tubing and Waterpath** on page 4.
- G** After the supply line has been thoroughly flushed, connect the water cooler to the water supply angle stop valve (not provided) with supplied 3/8" O.D. copper tube.
DO NOT OPEN (TURN ON) WATER SUPPLY STOP AT THIS TIME.
- H** Use supplied flexible hose and clamps to connect waste tailpiece from the upper unit to the waste tailpiece of lower unit and then make 1-1/4" O.D. P-trap waste connection. Waste P-trap not provided.
- I** **OPTIONAL, FOR FILTERED UNITS ONLY:** If you purchased a filtered unit, install the Water Filter Drop Down Door Kit according to the instructions packaged with the filter.

3 – INSTALL BOTTLE FILLER

- A** Remove bottle filler assembly and power supply from packaging. Be careful to avoid damage to unit and subassemblies. Set power supply aside in a secure location.

IMPORTANT: DO NOT PLUG IN TRANSFORMER UNTIL STEP 4D ON PAGE 8.

- B** Using a 5/32" hex driver or Allen wrench, unscrew the bottle filler housing from the mounting panel. Place the bottle filler housing and screws aside for later use.

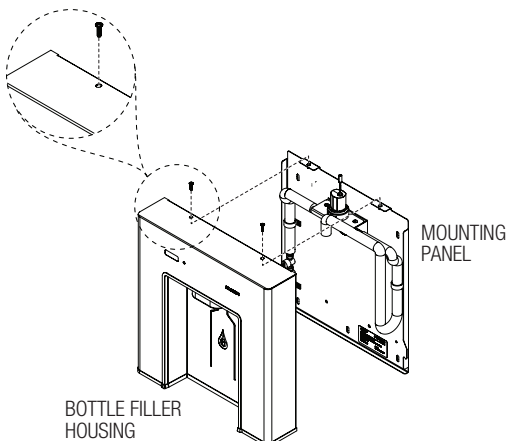

- C** Center the mounting panel on top of the lower cooler to finished wall. Secure with anchoring hardware (not provided) for 1/4" mounting holes.

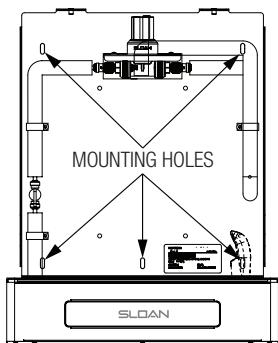

- D** Push the bottle filler power supply wire up through the grommet in the basin.

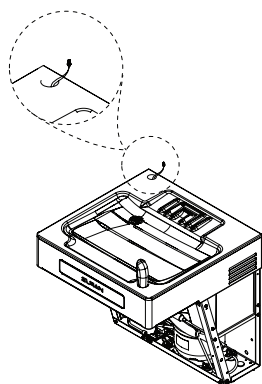

- E** Push free end of tubing from the bottle filler mounting plate down through the grommet.

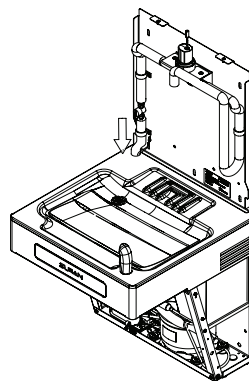

- F** Connect the bottle filler supply tubing to the push-in union tee located on the evaporator.

IMPORTANT: Route bottle filler tubing **behind** existing tubing.

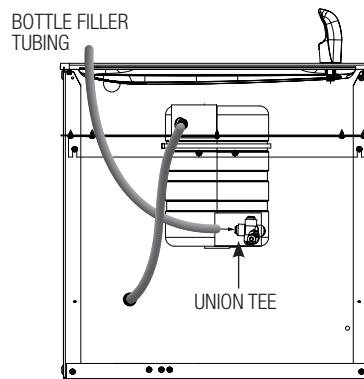

- G** With the mounting panel secured to the wall, place the bottle filler housing on top of the cooler and connect the water supply line from the bottle filler to the solenoid valve outlet.

- H** Connect the bottle filler power supply end connector to the power supply pigtail connector on the control board. Secure wire with cable tie.

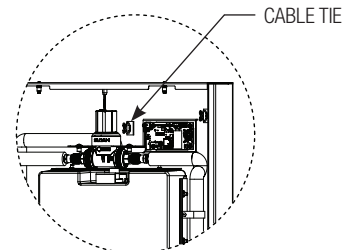

IMPORTANT: Once water and electrical connections are made, be careful when pulling the bottle filler housing away from the mounting panel as damage to the unit may result. If needed, disconnect water and electrical connections to separate the bottle filler housing and mounting panel completely.

4 – TURN ON WATER, PLUG IN POWER, AND STARTUP

A **IMPORTANT: DO NOT CONNECT ELECTRICAL POWER TO UNIT UNTIL STEP 4D.**

With bottom cover removed, and water supply thoroughly flushed of debris and air, turn on fixture water supply and check all connections for leaks.

B With power still NOT connected, carefully manually rotate cooling fan to ensure proper clearance and free fan action.

C Air within the system will cause an irregular bubbler outlet stream until purged out by incoming water. Thoroughly flush and purge air from supply line by depressing the push bar until steady water stream is achieved. Place a cup or towel over bubbler to prevent water spraying.

If needed, adjust the bubbler stream height. Insert a flathead screwdriver into the valve cartridge through the center of the push bar and rotate clockwise to increase stream height or counterclockwise to decrease height.

NOTE: For ADA compliance, the stream height must be a minimum of 4" high.

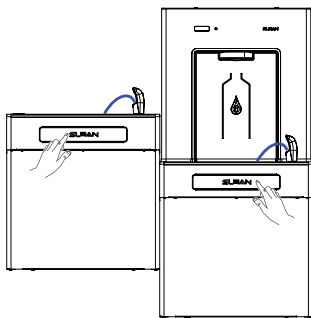

D Plug cooler power supply and bottle filler power supply into electrical outlets. Approximately 12 seconds after power up, the backlit LED lights will illuminate and the counter display will show the number of bottles saved. Bundle excess cord length if necessary.

IMPORTANT: DO NOT bundle bottle filler power cord and cooler power cord together. Keep power cords separated.

E **Set Filter Status**

Set new 3000 gal filter (filtered units) – Press service button for 3 seconds and release once “Reset Filter” is displayed on counter display. Quickly press and release button to change display to “Filter 3000”. Wait 6 seconds until display returns to the bottles saved value.

Unfiltered units – Press service button for 3 seconds and release once “Reset Filter” is displayed on counter display. Hold button for 3 seconds and release once “Filter NONE” is displayed on the screen. Wait 6 seconds until display returns to the bottles saved value.

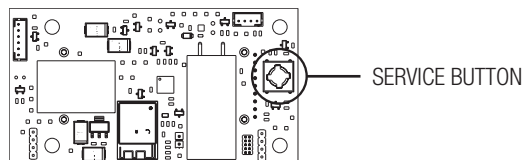
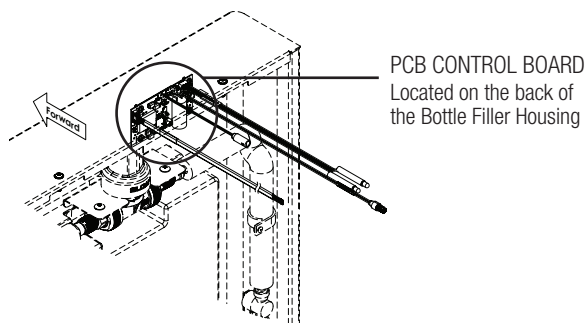

Sensor Range Adjustment

If needed, refer to the Adjustments & Settings section in the Repair Parts & Maintenance Guide for instructions: sloan.com/commercial-bathroom-products/bottle-fillers/dropspot/drs120

F **IMPORTANT:** Thoroughly inspect all unit connections for water leaks.

G Activate bottle filler to purge air.

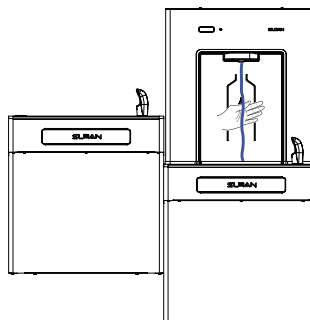

H Secure bottle filler housing to the mounting plate using the screws from Step 3B.

I **Assemble Bottom Covers to coolers.**

OPTIONAL: Attach trim bracket to the bottom cover if retrofitting an existing unit.

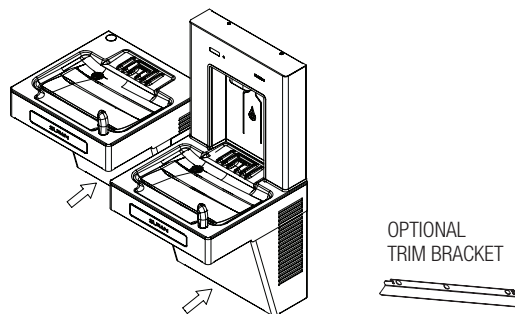

J **For Filtered Units Only**

Finish water filter setup and run 6.25 gallons through filter before use.

TROUBLESHOOTING GUIDE

IMPORTANT: BEFORE MAKING ANY OF THE REPAIRS LISTED, ENSURE PROPER ACCESS TO THE ELECTRICAL SUPPLY AND THE WATER SUPPLY VALVE IN THE EVENT THEY ARE NEEDED.

1. FLOW ADJUSTMENT:

- A. **Valve Cartridge** – The water flow can be adjusted using a flathead screwdriver and turning clockwise to increase flow and counterclockwise to decrease flow.

2. COMPRESSOR DOES NOT RUN:

- A. Check the electrical supply to verify power and correct voltage. The incoming voltage must be within 10% of the rated voltage on the serial nameplate.
- B. Check if the cold thermostat capillary bulb loses its charge or becomes kinked, it will fail in the open position causing a disruption of power to the compressor. Disconnect electrical supply to the water chiller and using an ohm meter, check for continuity across the two electrical terminals on the thermostat.
- C. Check for loose wires within the compressor box. The incoming power leads must be connected to the overload and relay.
- D. If all components check positive for continuity, then test the wiring harness plug for continuity to see if there is a broken wire within the wiring harness insulation.

3. COMPRESSOR RUNS - WATER IS WARM:

- A. The most common cause for a water chiller to run without producing cold water is a loss of refrigerant. The water chiller must be taken to a certified refrigerant technician for repairs.
- B. Disconnect power. Make sure the condenser fan motor is operative. The fan blade must turn freely to help remove the heat of compression.
- C. An incorrect refrigerant charge, restriction, or defective compressor (not pumping) will also cause the compressor to run without producing cold water. All these signs indicate a problem within the refrigeration system and the water chiller must be checked by an authorized service company.

4. COMPRESSOR CYCLING ON OVERLOAD PROTECTOR:

- A. Disconnect power. Check for a dirty condenser or a blocked fan, which causes a high head pressure and frequent cycling of the overload protector. Clean condenser and/or ensure the fan blade is rotating freely.
- B. Check the incoming voltage to make sure it is within 10% of the serial nameplate rating.
- C. Check for a restriction or moisture in the system. Contact a certified refrigeration mechanic in this situation.
- D. Change the overload or relay if defective.

5. NOISY OPERATION:

- A. Disconnect power. Check to make sure the fan blade is rotating freely.
- B. Check the compressor mounting to make sure the pins and clips are not rattling. If the compressor appears to be noisy internally, it must be replaced.

6. RESTRICTED OR NO WATER FLOW:

- A. Ensure water supply service stop valve is fully open.
- B. Verify minimum 20 psi supply line flow pressure.
- C. Check for twists or kinks in outlet tubing.
- D. Check strainer in push valve cartridge. The push valve cartridge located in the water control assembly or bubbler can also become clogged with foreign material. The push valve cartridge can only be replaced and not repaired. See **Preventative Maintenance** on next page.
- E. Check flow adjustment.
- F. Check if the solenoid strainer is clogged. If so, remove, clean, and reinstall strainer. Turn off the inlet water supply. Remove water supply line from inlet side of solenoid valve. Remove cap, water line fitting, gasket, strainer housing, and strainer from solenoid valve housing. Slide strainer off strainer housing. Clean strainer using fresh tap water only. If necessary, use a small brush to clean. Use caution while cleaning to prevent damage to strainer. If any strainer components are damaged, replace as necessary. Reinstall strainer on strainer housing. Install strainer housing, gasket, water line fitting, and cap onto solenoid valve housing. Tighten cap securely. Reinstall water supply line to inlet side of solenoid valve.
- G. Check if bottle filler spout is clogged. If so, remove, clean, and reinstall.

- H. Check if the water chiller has developed a freezing condition in which the water will become frozen inside the evaporator coil. This indicates a refrigeration problem or thermostat failure; in which case, the water chiller needs to be checked by a qualified technician.

- I. Check the shut-off valve, water activated. If it's tripped, the lever will be horizontal and the puck will be swollen. If tripped, replace puck.

- J. Ensure there is power to the transformer by checking connections and for loose, or cut wires.

- K. For filtered units, check water filter. Replace if necessary.

7. BOTTLE FILLER DOES NOT DELIVER ANY WATER WHEN ACTIVATED:

- A. Confirm that solenoid valve produces an audible "CLICK." If it doesn't, then move to 7F.

- B. Check if water supply stop is closed. If so, open supply stop.

- C. Check if shut-off valve is closed. If so, open shut-off valve.

- D. Bottle filler spout is clogged. Remove and clean.

- E. If solenoid valve DOES NOT produce an audible "CLICK," then check the following.

- F. Check if DC power adapter is disconnected. If so, reconnect, otherwise power cycle by unplugging the power adapter and plugging it back into the unit.

- G. Check solenoid cable harness connection to PCB. See wiring diagram on page 4.

- H. Sensor failure. Red LED sequence on sensor (see **SENSOR LED DIAGNOSTIC PATTERNS**). Replace sensor.

8. BOTTLE FILLER DOES NOT STOP DELIVERING WATER OR CONTINUES TO DRIP AFTER USER IS NO LONGER DETECTED (AUTOMATIC SHUT-OFF FAILS EVEN WHEN POWER IS DISCONNECTED):

- A. Check if solenoid valve is connected backwards. If so, disconnect solenoid valve compression fittings at both the inlet and outlet positions. The water should flow from inlet through the solenoid valve to the outlet according to the direction of the arrow shown on the side of the solenoid valve. Reconnect the compression fittings in the correct orientation.

- B. Check if solenoid valve is dirty. If so, backflush the solenoid by reversing water flow (opposite to the direction shown by the arrow on the side of the solenoid valve) through the solenoid valve. Reconnect the compression fittings in the correct orientation.

9. BACKLIT LEDS ARE OFF OR FLICKERING:

- A. Check if bottle filler spout harness is disconnected. Check bottle filler spout cable harness connection to PCB. Replace harness if problem persists. See wiring on page 4.

10. COUNTER DISPLAY OFF OR DISPLAYING "INVALID SENSOR":

- A. Unit is in lockout mode. Power cycle by unplugging the power adapter and plugging it back into the unit.

- B. Confirm that the sensor harness is not disconnected.

SENSOR LED DIAGNOSTIC PATTERNS:

Red LED Pattern on Sensor	Pattern Meaning	Action
Single 1 second long blink at startup	Beginning startup sequence	N/A
3 separate quarter-second blinks with half-second blinks between each blink. 1.25 seconds after the 3 blinks before pattern starts again	Sensor invalid/failure	Check sensor harness, power cycle unit, replace sensor
0.05 second blinks every quarter-second	Target detected (only occurs in the first 10 minutes after power up)	N/A

When assistance is required, please contact Sloan Technical Support at 1.888.SLOAN.14 or 1.888.756.2614.

PREVENTATIVE MAINTENANCE

PUSH VALVE CARTRIDGE REPLACEMENT AND STRAINER MAINTENANCE

- 1 Insert the Universal Maintenance Tool into the center hole of the push bar to swing the push bar upwards and open.
- 2 Strainer cap must be removed before push valve cartridge replacement and strainer maintenance (no need to turn the water off at the angle stop). Some residual water will drain during cap removal.
- 3 Clean strainer as needed using clean water.
- 4 Push Valve Cartridge Replacement – Remove retaining nut. Remove and replace push valve cartridge. When replacing push valve cartridge, be sure to align the inlet and outlet ports on the push valve cartridge with the ports in the valve body.

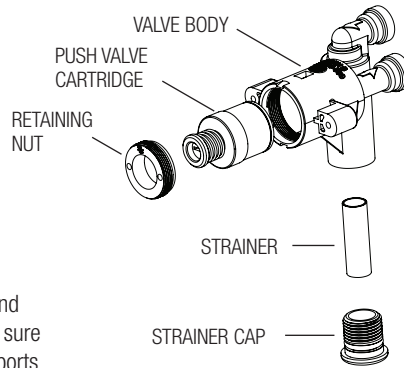

NOTE: STRAINER SCREEN MUST BE IN PLACE FOR WATER TO FLOW.

REPLACE WATER FILTER - FILTERED UNITS ONLY

If water becomes cloudy, decreased water flow or pressure, and/or the water develops a bad taste, change the water filter. Refer to the installation instructions packaged with the water filter.

CLEAN DEBRIS FROM CONDENSER

Clean with vacuum if needed to keep compressor running efficiently. Use compressed air to remove any dust buildup.

For additional maintenance information, refer to the Repair Parts & Maintenance Guide: sloan.com/commercial-bathroom-products/bottle-fillers/dropspot/drs110

CARE AND CLEANING

IMPORTANT: DO NOT MIX CLEANING SOLUTIONS. ALWAYS READ CLEANING PRODUCT LABEL FOR PROPER USE.

FOR STAINLESS STEEL UNITS

Use only a mixture of clean water and a mild detergent to clean unit weekly or more often as needed. For best results, always rinse well with fresh water and wipe completely dry with a clean soft cloth. **DO NOT USE** harsh chemicals, abrasive, or petroleum based cleaners. Use of these will void the Sloan warranty. To remove stubborn water marks or minor scratches, apply a stainless steel cleaner/polish to a synthetic abrasive pad and carefully rub the panel with the grain. **ALWAYS RUB IN THE DIRECTION OF THE GRAIN.** To disinfect stainless steel surfaces, use a solution of clean water and rubbing alcohol. Spray solution onto a soft cloth and wipe down the surfaces of the Bottle Filling Station. Wipe completely dry with a separate clean, dry cloth. Be sure to always wipe or rub **in the direction of the grain** to maintain the finish.

FOR NON-STAINLESS STEEL UNITS

Use only a mixture of clean water and a mild detergent to clean unit weekly or more often as needed. For best results, always rinse well with fresh water and wipe completely dry with a clean soft cloth. **DO NOT USE** harsh chemicals, abrasive, or petroleum based cleaners, abrasive brushes or pads, or hot water/cleaning solutions. Use of these can damage the finish causing corrosion and will void the Sloan warranty.

FOR CHILLER UNITS

Exterior panels can be cleaned using a mild soap and clean water. **DO NOT USE** harsh chemicals, abrasive, or petroleum based cleaners. Use of these will void the Sloan warranty. Motors include lubrication for lifetime of product and do not require replenishment. Excess dirt or poor ventilation will cause the compressor overload protector to turn the compressor off and it will cycle on and off with no cold water coming out of the Bottle Filler. Periodically clean condenser fins and cabinet ventilation louvers with vacuum cleaner, air hose or brush. In environments where dirt and dust is more prevalent, clean more frequently.

FCC COMPLIANCE

CAUTION: Changes or modifications not expressly approved could void your authority to use this equipment. This device complies with Part 15 of the FCC Rules. Operation to the following two conditions: (1) This device may not cause harmful interference, and (2) this device must accept any interference received, including interference that may cause undesired operation. Note: This equipment has been tested and found to comply with the limits for a Class C digital device, pursuant to part 15 of the FCC Rules.

INDUSTRY CANADA STATEMENT

This device complies with Industry Canada license-exempt RSS standard(s). Operation is subject to the following two conditions: (1) this device may not cause interference, and (2) this device must accept any interference, including interference that may cause undesired operation of the device. Le présent appareil est conforme aux CNR d'Industrie Canada applicables aux appareils radio exempts de licence. L'exploitation est autorisée aux deux conditions suivantes : (1) l'appareil ne doit pas produire de brouillage, et (2) l'utilisateur de l'appareil doit accepter tout brouillage radioélectrique subi, même si le brouillage est susceptible d'en compromettre le fonctionnement. et votre corps. Cet appareil et son (ses) antenne (s) ne doivent pas être co-localisés ou utilisés conjointement avec une autre antenne ou un autre émetteur.

PARTS LIST — COOLERS

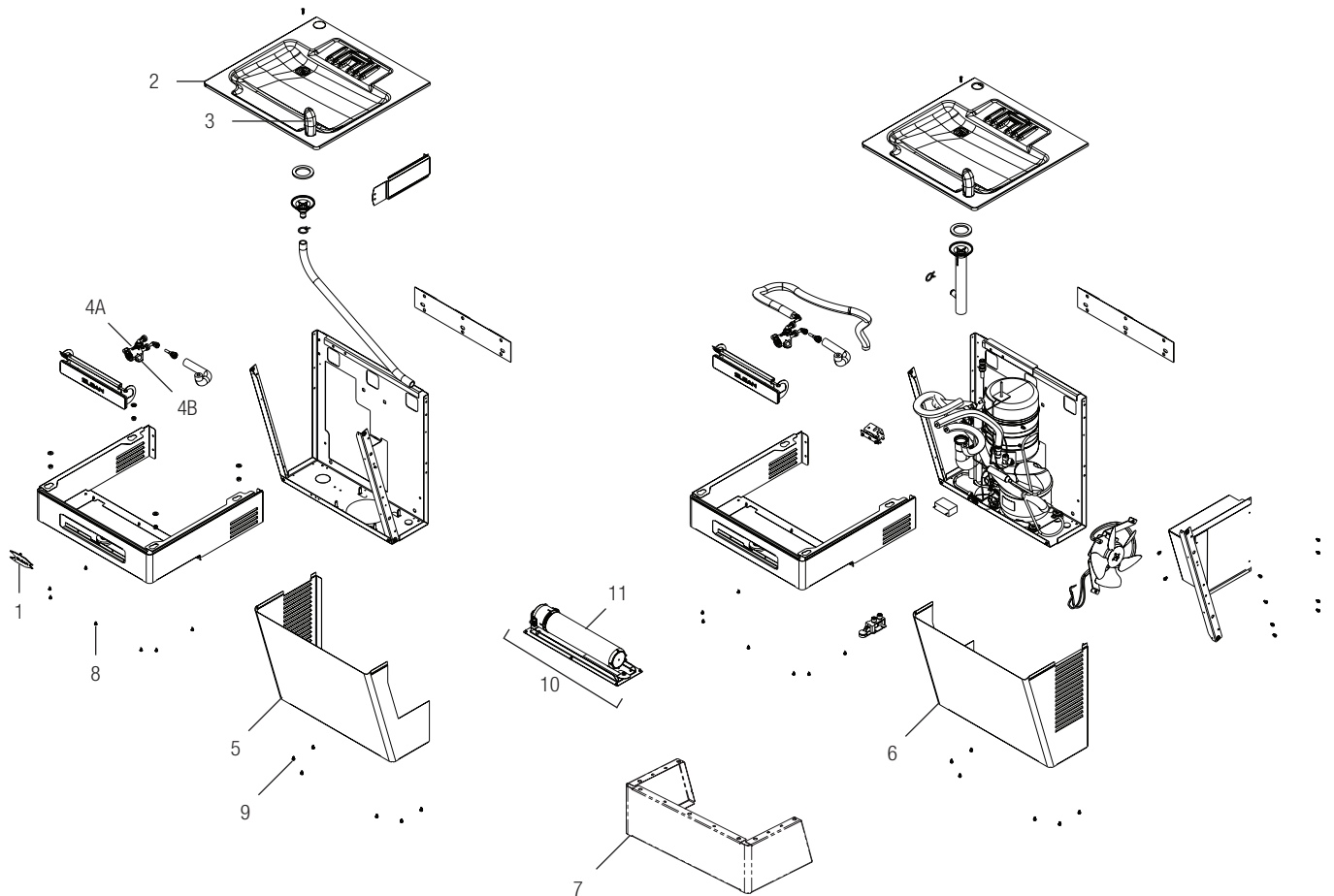

Item No.	Code No.	Part No.	Description
1	33830015	BFS-1	Universal Maintenance Tool
2	33830035	BFS-18	Drinking Fountain Basin Assembly (Qty 2)
3	33830018	BFS-4	Bubbler Assembly (Qty 2)
4A	33830016	BFS-2	Push Valve Replacement Kit (Qty 2)
4B	63830017	BFS-3	Push Valve Strainer Replacement Screen (Qty 2)
5A	33830020	BFS-6	Lower Cabinet, Left - Stainless Steel
5B	33830023	BFS-9	Lower Cabinet, Left - Black
6A	33830021	BFS-7	Lower Cabinet, Right - Stainless Steel
6B	33830024	BFS-10	Lower Cabinet, Right - Black
7A†	33830030	BFS-16	Cane Apron - Stainless Steel
7B†	33830031	BFS-17	Cane Apron - Black
8	—	—	#8 x 3/8" Stainless Steel Phillips Head Sheet Metal Screw (Qty 14)

† Sold Separately

Item No.	Code No.	Part No.	Description
9	—	—	#8 x 3/8" Hex Washer Head Screw, Zinc, Slotted (Qty 30)
10	33830002	FA3000-DRS110/DRS120	Optional PFAS Water Filter Upgrade Kit
11A	33830003	FC3000R	Optional PFAS Water Filter Replacement Filter - 1 pack
11B	33830014	FC3000M	Optional PFAS Water Filter Replacement Filter - 20 pack
—	33830032	BFS-30	Cooler Replacement Unit Stainless Steel - DRS120
—	33830033	BFS-31	Cooler Replacement Unit Black - DRS120

PARTS LIST — BOTTLE FILLER

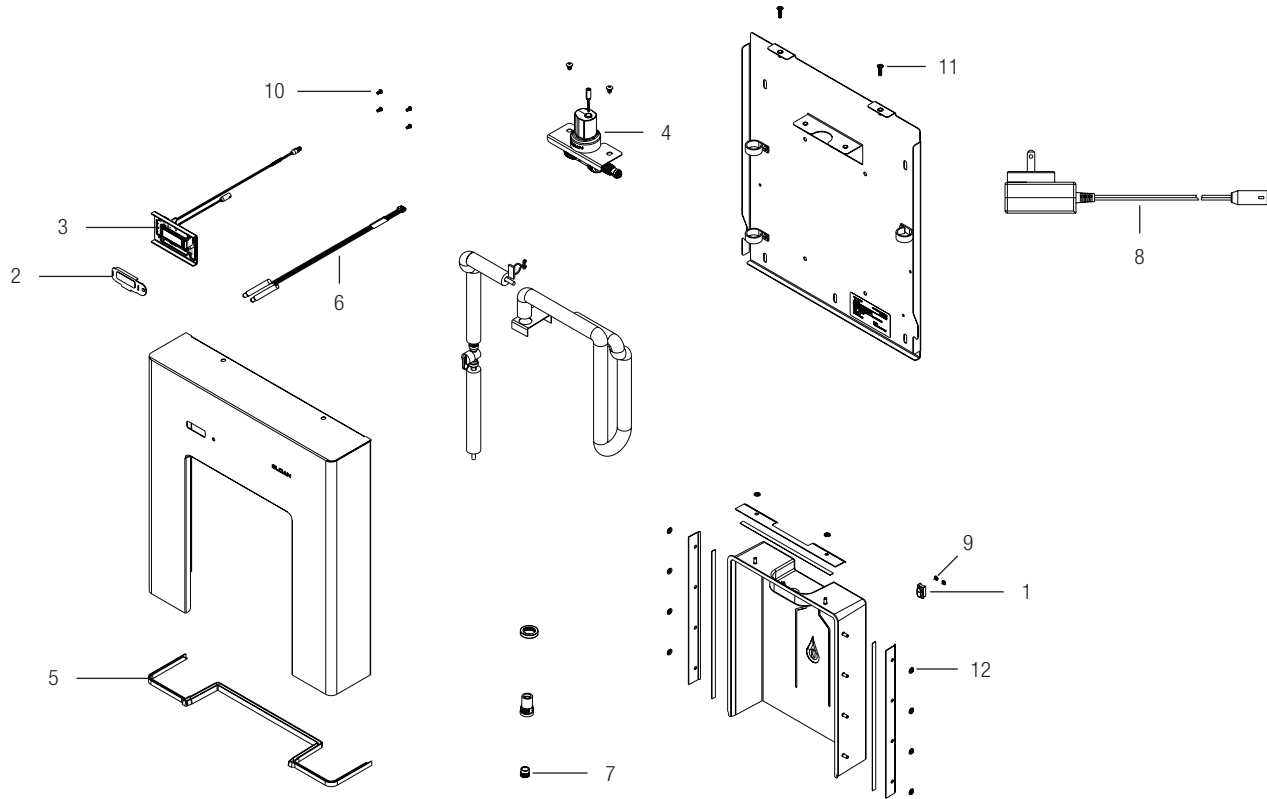

Item No.	Code No.	Part No.	Description
1	33830011	BFS-26	Sensor Replacement
2	33830025	BFS-11	Counter Display Cover Replacement
3	33830041	BFS-25	Sensor PCBA Control Board - DRS-120
4A	63820001	BFS-1001A	Solenoid Valve Assembled
4B	3344001	ELG-1002	Solenoid Valve Repair Kit
4C	33830046	—	Solenoid Replacement Kit
5	33830027	BFS-13	Splash Gasket Replacement DRS-110/120
6	33830012	BFS-27	Spout Outlet LED
7	33830026	BFS-12	1.2GPM Laminar Sprayhead Replacement
8	33830034	BFS-22	110-240 VAC/6 VDC Power Supply

Item No.	Code No.	Part No.	Description
9	—	—	Sheet Metal Screw, #6x. 188, Truss Head S/S (Qty 2)
10	—	—	S/S Philips Round Head Screw, #6-32 UNC X 3/8" (Qty 4)
11	—	—	1/4"-20 X 3/4" Flanged Button Head Screw (Qty 2)
12	—	—	#10-32 X 3/8: S/S Truss Philips Head Screw (Qty 2)
—	33820003	DRS120-UNFIL-REF-SS	Full Unit - Non-Filtered, Refrigerated, Stainless Steel
—	33820027	DRS120-UNFIL-REF-BLK	Full Unit - Non-Filtered, Refrigerated, Black
—	33820006	DRS120-FIL-REF-SS	Full Unit - Filtered, Refrigerated, Stainless Steel
—	33820030	DRS120-FIL-REF-BLK	Full Unit - Filtered, Refrigerated, Black

The information contained in this document is subject to change without notice.

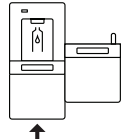

Register your Sloan DropSpot™ Bottle Filler.

Go to sloan.com/register or scan the QR code and enter your serial number found under unit.



SLOAN • 10500 SEYMOUR AVENUE • FRANKLIN PARK, IL 60131

Phone: +1.800.9.VALVE.9 or +1.800.982.5839 • Fax: +1.800.447.8329 • www.sloan.com