

INSTALLATION INSTRUCTIONS FOR DROPSPOT™ FILTER DROP-DOWN KIT



FA-3000

3000 Gallon Water Filter (FC3000R) and Drop-Down Kit
Assembly for DRS-110 and DRS-120 Bottle Fillers

FC3000R is certified by IAPMO R&T to NSF/ANSI 42, NSF/ANSI 53, and NSF/ANSI 401 for the reduction of particulate class I, lead, and cyst when used in FA3000-DRS110 and DRS120.



SLOAN® LIMITED WARRANTY SUMMARY

Sloan Valve Company ("Sloan"), warrants its products against defects in materials and workmanship, excluding damage caused by matters beyond Sloan's reasonable control. Instructions for filing claims can be found in the Limited Warranty which can be obtained at www.sloan.com or by requesting a free copy by telephone at 888.756.2614. Sloan will repair or replace your defective product, or provide a refund, as your exclusive remedy. This is only a general summary of Sloan's Limited Warranty so it is important to note that the specific terms, conditions, limitations and exclusions, including the duration of warranty coverage for your particular Sloan product, are contained in the actual Sloan Limited Warranty. The Limited Warranty is subject to applicable laws in your country, state, province or other jurisdiction—and disputes arising under the Limited Warranty are to be resolved by binding arbitration unless you provide Sloan with an opt-out notice no later than 30 days after your purchase date. In case of a conflict with this summary, the terms and conditions set forth in the complete Limited Warranty will prevail.

IMPORTANT INFORMATION

- Install in compliance with local and state regulations.
- Install in cold water applications only.
- DO NOT USE where the water is microbiologically unsafe or of unknown quality without adequate disinfection before or after the unit.
- DO NOT USE this system on water containing hardness greater than 50 mg/L (3 grains per gallon) without pretreatment to remove hardness.
- Rated maximum service flow = 1.25 gpm
- Maximum operating pressure = 125 psi
- Maximum operating temperature = 130°F
- Spent absorption media should not be regenerated and used.
- If absorption media is affected by chlorine, influent should be treated to remove chlorine.
- **WARNING:** This system is for use on water supplies that have been treated to public water systems standards. This system has been tested to demonstrate effective reduction of microcystins, however, in the event of a reported cyanotoxin event in your water supply, other cyanotoxins may be present in the drinking water which may not be effectively reduced by this system. In the event of a cyanotoxin notification, follow the recommendations of your drinking water authority.
- This system conforms to NSF/ANSI 53 and has been verified and substantiated by test data.

TOOLS REQUIRED FOR INSTALLATION

- Flathead screwdriver or nut driver for screws in Step 1 (not provided)
- Phillips screwdriver for screws in step Step 3 (not provided)
- Universal Maintenance Tool (provided with bottle filler)

Universal Maintenance Tool
DO NOT DISCARD!



INSTALLATION INSTRUCTIONS

IMPORTANT: The Sloan Universal Maintenance Tool is required to install the Filter Drop-Down Kit. The Universal Maintenance Tool is packaged with the installation instructions furnished with the Bottle Filler unit. **DO NOT DISCARD.**

- 1 Remove the lower cover from cooler and set aside with screws for later use.
- 2 Turn off water supply at shut-off valve.
- 3 Remove filter access panel. Set aside screws for later use.

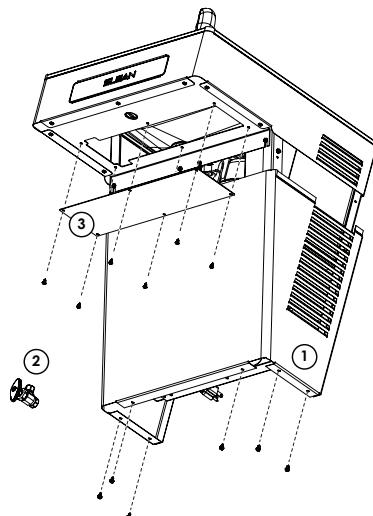

- 4 Locate the water supply line through the opening of the filter access panel.

Double check to ensure the water supply is turned off.

Remove and discard push-in coupler fitting to insert filter.

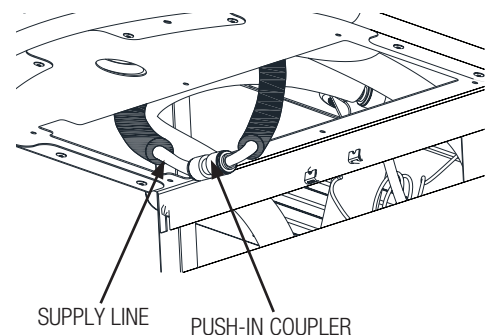

INSTALLATION INSTRUCTIONS, CONTINUED

- 5 Disconnect the push-in fitting using the Universal Maintenance Tool by pushing the collet square towards the push-in fitting body and hold. While pushing the collet in, pull on the tubing to remove from the push-in fitting. Repeat for opposite side.

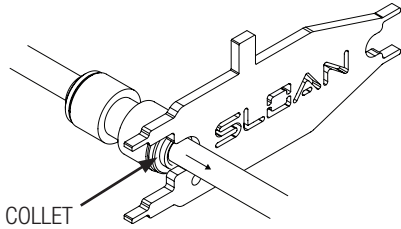

- 6 Insert the end from the supply line inlet into the push-in fitting, approximately 1/2" deep.

IMPORTANT: Insert water line on push-in stem with corresponding flow line.

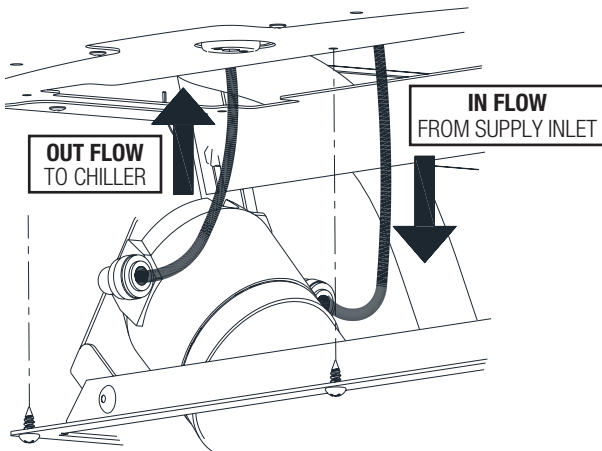

PIPING SCHEMATIC

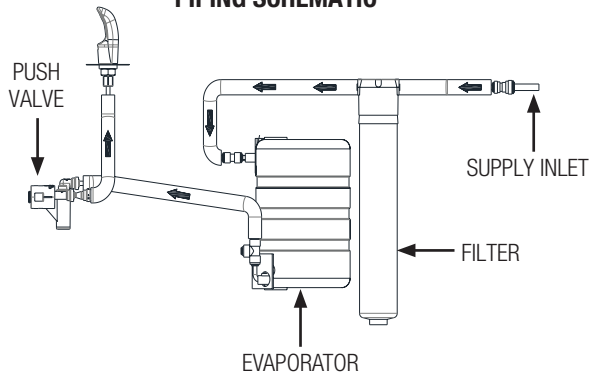

When assistance is required, please contact Sloan Technical Support at 1.888.SLOAN.14 or 1.888.756.2614.

- 7 Gently pull on the fitted tubing to ensure it is secure. Tube should not come free from the fitting.

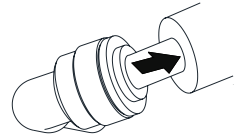

- 8 Install the drop-down filter frame using the six (6) screws from Step 3.

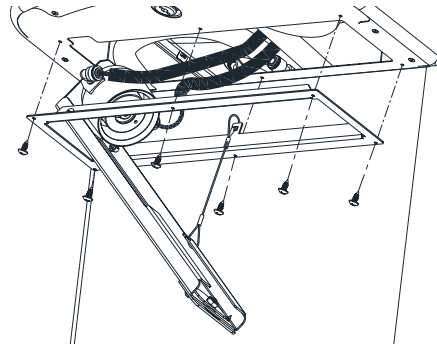

- 9 Swing Filter unit up and lock using the Universal Maintenance Tool.

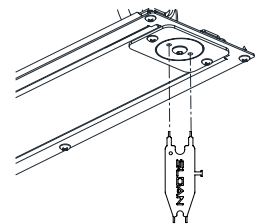

- 10 Turn on water supply.

IMPORTANT: Thoroughly check for leaks before proceeding.

- 11 Reinstall Lower Cover using the six (6) screws from Step 1.

IMPORTANT

Run 6.25 gallons of water through the filter before use.
Change the filter when the LED is illuminated, or if water becomes cloudy, decreased water flow or pressure, and/or the water develops a bad taste. See Replacement Filters table below.

REPLACEMENT FILTERS (SOLD SEPARATELY)		
Code No.	Part No.	Description
33830003	FC3000R	3000 Gallon Filter Cartridge (1 pack)
33830014	FC3000M	3000 Gallon Filter Cartridge (20 pack)

The information contained in this document is subject to change without notice.